

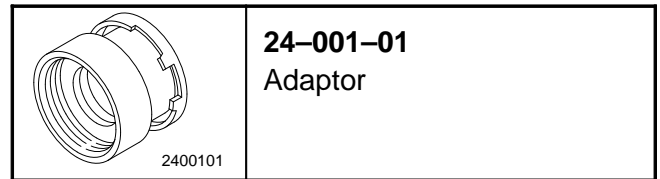

Cooling System – Pressure Test (24 111 0)

Special Tools

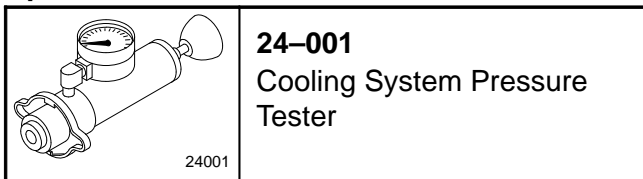

Test

1. **Start the engine and allow it to reach its normal operating temperature.**

 **WARNING:** When releasing the system pressure, cover the cap with a thick cloth to prevent the possibility of scalding.

2. **Stop the engine and relieve the cooling system pressure by slowly turning the expansion tank cap a quarter turn.**

3. **Remove the cap when all pressure has been released.**

4. **Connect the cooling system pressure tester to the expansion tank.**

Use the correct adaptors and ensure that a good seal is created between the tester and the expansion tank.

5. **Pressurise the system and hold for ten seconds.**

If the pressure drops within this time, inspect the cooling system for leaks and rectify.

6. **Release the pressure and remove the tester.**

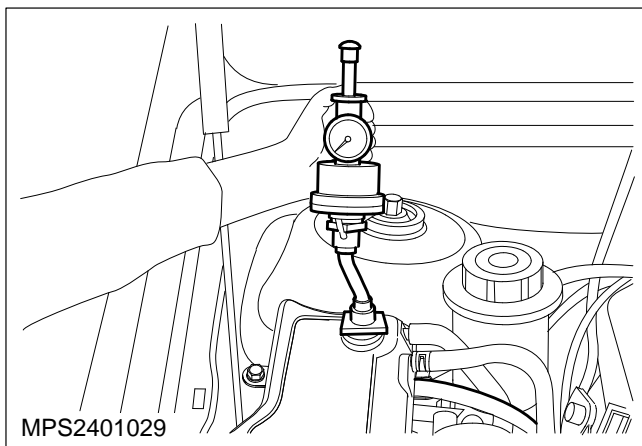

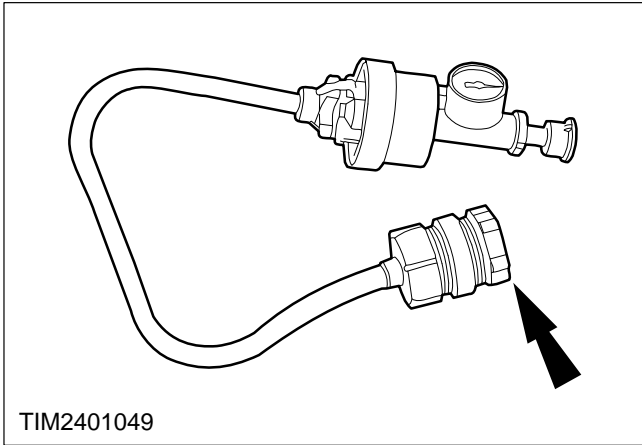

7. Fit the appropriate pressure test adaptor to the cap and assemble on the tester.

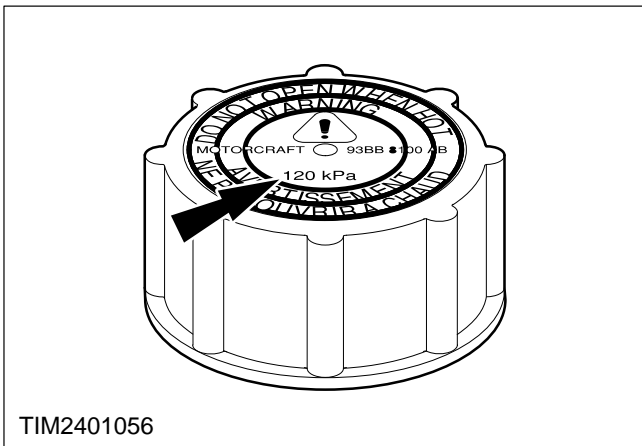

8. Pressurise the tester and note the maximum steady pressure achieved.

The pressure relief specification is printed on the cap. Replace the cap if necessary.

9. Remove the cap from the pressure tester.

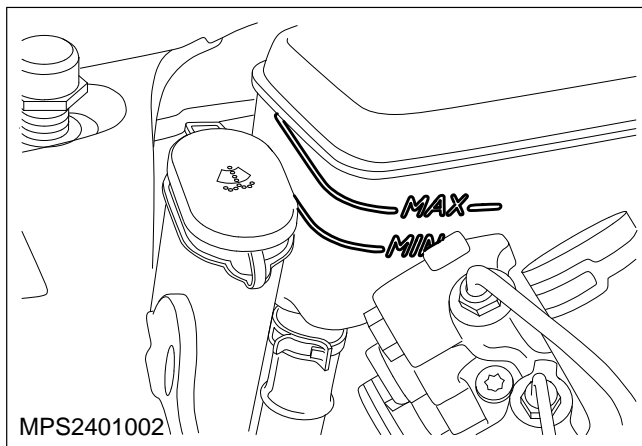

10. Check the coolant level and top up to the maximum mark if necessary.