

Module – Immobiliser (PATS) – Remove and Install (33 660 0)

Remove

⚠ CAUTION: Disconnect the battery negative lead.

1. Remove the glove compartment (refer to Operation Number 43 668 0).

2. Remove the carpet trim.

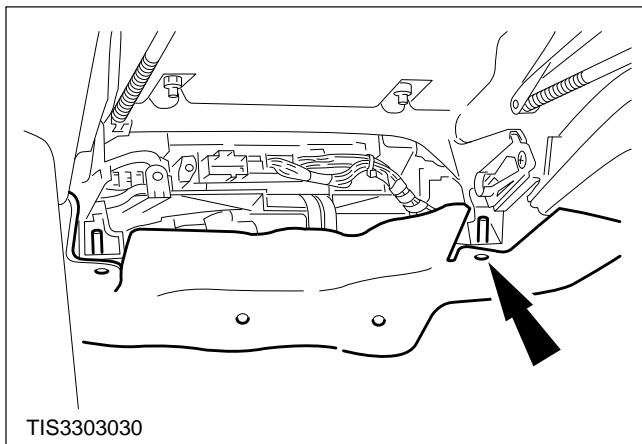

3. Detach the powertrain control module.

- 1 Unclip the module.
- 2 Detach the module.

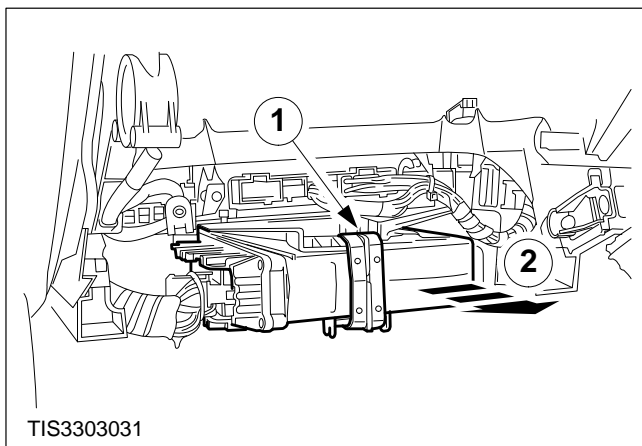

4. Detach the floor covering.

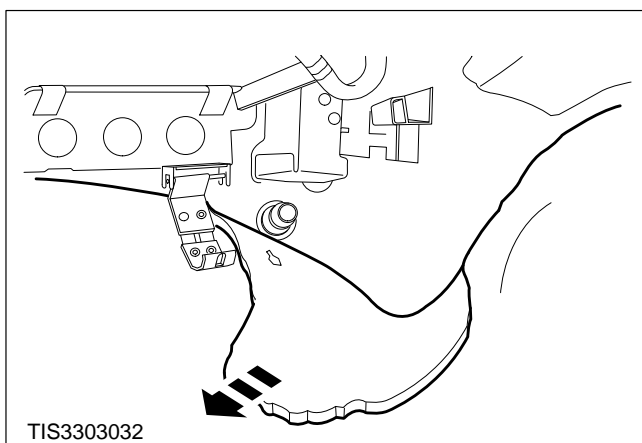

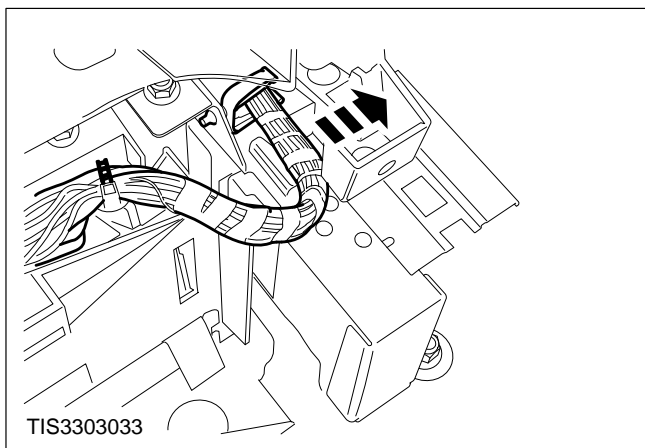

5. Detach the wiring harness.

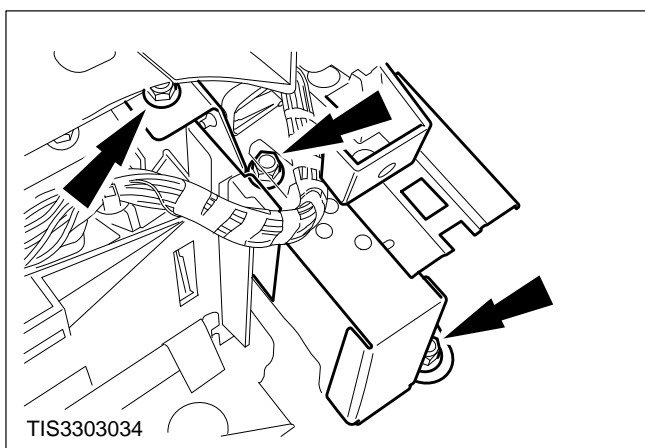

6. Detach the bracket (three nuts).

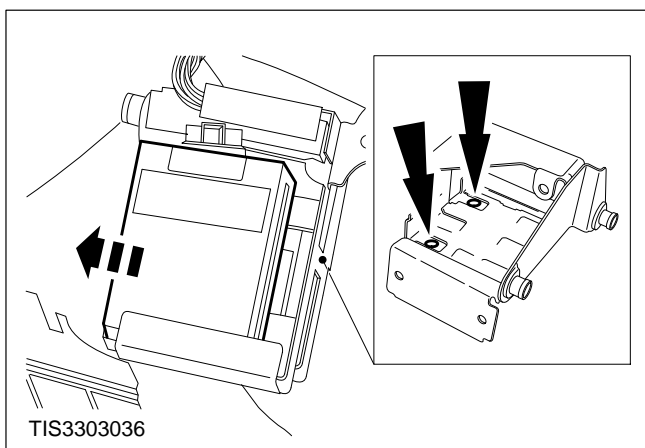

7. Detach the PATS module.

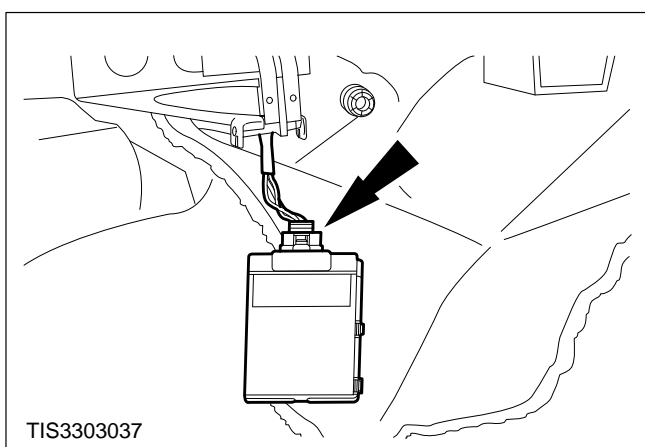

8. Disconnect the multiplug and remove the PATS module.

Install

NOTE: FDS 2000 must be used to configure a new PATS module on VM diesel variants. To carry out this procedure, run the Configure menu item from the main menu.

9. Refit the components in reverse order.