

Engine Compression – Check (engine hot) (21 111 0)

Workshop Equipment

Compression pressure recorder	623.000.1004
-------------------------------	--------------

Materials

Spark plug lubricant (“Never Seez”)	ESE-M12A4-A
-------------------------------------	-------------

Check

NOTE: Because of the different build styles of the compression pressure testing equipment and varying starter motor speeds, it is often only possible to check that the compression pressure is the same in each cylinder. A measurement of the actual compression pressure depends on several factors, and requires certain preconditions:

- The engine should be at normal operating temperature.
- The hydraulic tappets must operate correctly. If necessary crank the engine for a few seconds to supply the hydraulic tappets with oil.
- The battery must be correctly charged.

1. Open the central electrical box.

2. Remove the fuel pump relay.

3. Start up the engine.

The engine will start, run for a few seconds and then stall.

4. Disconnect the spark plug connectors.

5. Remove the spark plugs.

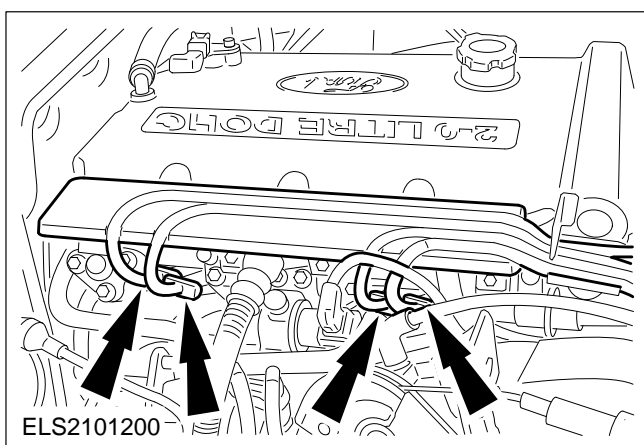

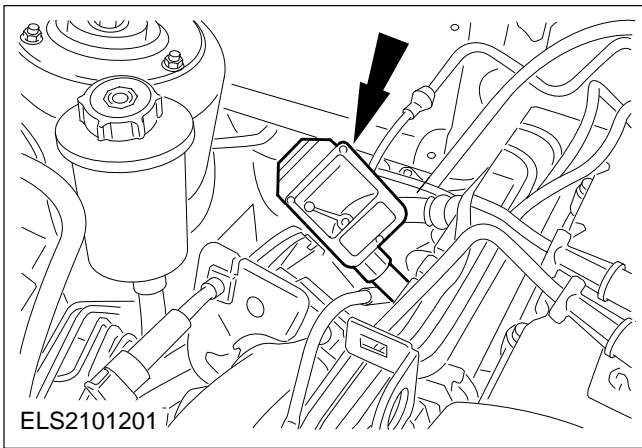

6. Fit the compression pressure gauge.

NOTE: Crank the engine on the starter motor until the pointer on the meter stops rising.

7. Measure the compression pressure.

Carry out the measurement on all cylinders in accordance with instructions supplied with the measuring device (cylinder no. 1 shown).

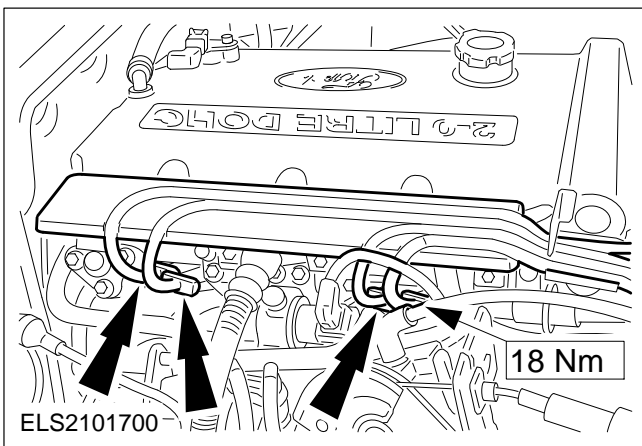

NOTE: Coat the spark plug threads with lubricant (ESE-M1244-A).

8. Fit the spark plugs.

9. Connect the spark plug connectors.

10. Fit the fuel pump relay.

11. Close the central electrical box.

12. Connect FDS2000 and reset fault memory.